

## E200 Series Electric Level Control Switch

### Application - High & Low Liquid Level Control; WP 1500 psig to 5000 psig

- Float-actuated Electric Switch for High, Low or Interface Level Control
- Provides Electric Switch input for control systems, alarms or other switch operations
- Use on production separators, heaters/treaters, scrubbers, liquid accumulators & process vessels
- 316 Stainless Steel construction for use with most Liquids or Liquid Interfaces
- Low Specific Gravity of 0.5 and above; 0.4 with counterweight
- Interface as low as 0.1 Specific Gravity differential
- Direct mounting inside vessel or External Float Cage

### Features and Benefits of the E200 Series

- Manual Override available for in-service Field Testing
- Single Seal Application Approved
- 316 SS wetted components for Durability and Corrosion Resistance
- Explosion Proof Certification by CSA to USA and Canada Standards
- Hermetically Sealed Reed Switch Cartridge to protect Integrity of Switch Contacts
- SPST and SPDT Switch Cartridges in Standard and Light Load Ratings
- No Internal Seal used on standard body thus eliminating the possibility of process fluid leakage
- Few Moving Parts for Reduced Maintenance and long term Performance
- Excellent Serviceability including Quick Replacement of Electric Switch Cartridge
- Displacer options for various Pressure, Specific Gravity, and Interface applications
- Normally Open or Closed operation by simply inverting Level Control unit
- Relay Assembly in Explosion Proof enclosure for DPDT and Higher Amperage service

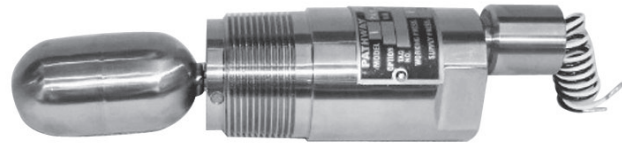

### E200 Common Options

- 316 SS and 304 SS flanged connections
- Float arm extensions on standard and extended body styles
- Relay for DPDT and Higher Amperage
- Light Load Switch for PLC and low wattage Applications
- Counterweight for lower S.G.
- Annulus plug for use with sediments
- TFE Coating
- SS Lanyard & Tag

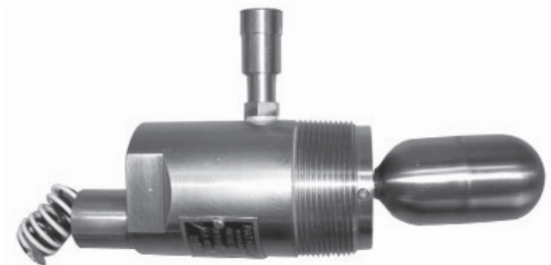

### Benefits of ALL Pathway Control Products

- Personalized Service and Support expertise
- Responsive On-time Delivery
- Time-tested & Proven design providing Dependable, Long-term service
- Made in USA

## E200 Series Electric Level Control Switch

### Sample Models

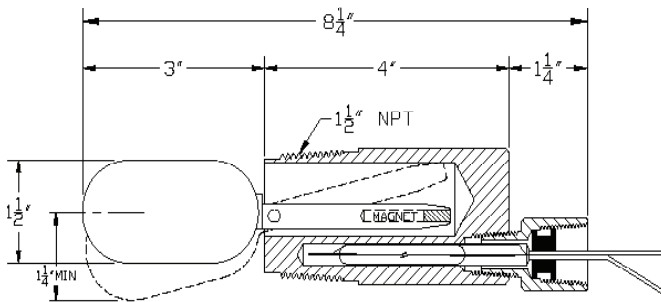

Model: E200-01-00

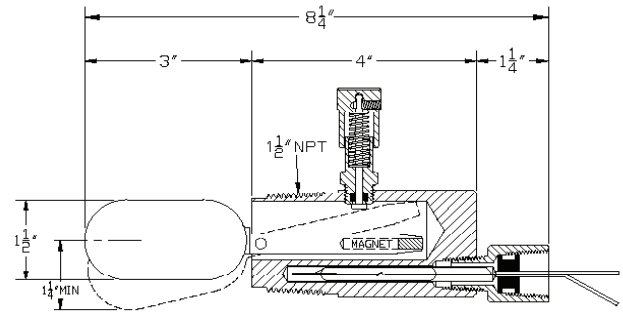

Model: E200-21-00

### Specifications

<b>Working Pressure:</b>	1500 psig; available up to 5000 psig; 1500 psig with manual override 1500 psig to 3000 psig with Ring Bolted Cage
<b>Temperature:</b>	-40° F to +392° F with SS Float; 180° F max with polypropylene displacer
<b>Specific Gravity:</b>	0.5 minimum; 0.4 with counterweight; interface 0.1 differential minimum
<b>Switch Ratings:</b> SPST & SPDT	
Standard Load:	250V – 0.40A resistive, 120V – 0.83A resistive, 24V – 3.0A resistive; 3.0A maximum in-rush capability; 4 watts minimum for proper switching
Light Load:	150V – 0.17A resistive, 110V – 0.23A resistive, 24V – 1.0A resistive; 1.0A maximum in-rush capability; 0.1 watts minimum for switching
<b>Materials:</b>	316 Stainless Steel Wetted components; Hermetically sealed reed switch
<b>Process Connection:</b>	1 1/2" NPT, 2" NPT, Ring Bolted on E200C, or 3" flanged or larger
<b>Electrical Connection:</b>	1/2" NPT conduit
<b>Certification:</b>	CSA: Class I, Div. 1, Groups A, B, C, D; Class II, Div. 1, Groups E, F, G; Class III, Div. 1 to USA & Canada Standards; (rating with relay enclosure Class I, Div. 1&2, Groups C,D; Class II, Div. 1, Groups E,F,G; Class II, Div. 2, Groups F,G; Class III ) CSA: Single Seal applications per ANSI/ISA 12.27.01-2003

## E200 Series Electric Level Control Switch

### Ordering Chart Example:

**E200- 0 1 - 0 0**

(#) Option #, see Special Materials & Features below

E200 SERIES	
Electric Level Control Switch	

or

E200C	
Ring Bolted Body External Cage; WP 1500 psig to 3000 psig (body style 0)	

BODY STYLE	
0	1½" NPT body or Ring Bolted on E200C (no manual override on E200C)
1	2" NPT
2	1½" NPT, manual override*
3	Extended body, 2" NPT, vertical displacer/ float (type 3,7,8 ,9)
4	2" NPT, manual override*
6	Extended body, 2" NPT, manual override*, vertical displacer/float (type 3,7,8 ,9)
7	Extended body, 2" NPT, horizontal displacer/ float (type 3,7,8 ,9)
8	Extended body, 2" NPT manual override*, horizontal displacer/float (type 3,7,8 ,9)
*WP 1500 psig on manual override	

FLOAT/DISPLACER TYPE	
1	316 SS standard float, WP 1500 psig, 0.5 SG min (body style 0, 1, 2, 4)
2	Polypropylene high pressure displacer, WP 5000 psig standard, 3000 psig on E200C, +180° F max temp; 0.6 SG min (body style 0, 1, 2, 4)
3	Interface Polypropylene displacer, WP 5000 psig standard, 3000 psig on E200C, +180° F max temp; upper fluid < .870 SG, lower fluid > .970 SG
4	Customer defined SG for upper and lower fluid interface
6	316 SS higher pressure float, WP 2000 psig, 0.63 SG min (body style 0, 1, 2, 4)
7	316 SS 2" X 6" float, WP 250 psig
8	316 SS 2" X 6" float, WP 1500 psig
9	Polypropylene high pressure displacer, WP up to 5000 psig, +180° F max temp, 0.5 SG min (extended body style 3, 6, 7, 8)

OTHER SELECTIONS (add as needed)	
0	No other options
2	Annulus plug
3	Relay assembly general purpose plug-in, 24VDC DPDT 10 Amp
4	Relay assembly general purpose plug-in, 120VAC DPDT 10 Amp
8	Relay assembly hermetically sealed plug- in, 24VDC DPDT 12 Amp
9	Relay assembly hermetically sealed plug- in, 120VAC DPDT 12 Amp
5	Customer Specified Requirements <i>For Example:</i> Stainless steel flanged connection (304 SS & 316 SS) Counterweight for lower SG Float arm extension (specify length) Extended cable length for vertical float/displacer Monel standard size E200 Float Custom float sizes Interface polypropylene displacer for external cage Weld SS float to float arm Ring bolted body without external cage Cable pull for manual override ID tag with lanyard (304 SS & 316 SS)

SWITCH SELECTION	
0	SPST standard load
1	SPDT standard load
2	SPST light load
3	SPDT light load
4	SPST standard load, 36" lead wires
6	SPDT standard load, 36" lead wires

SPECIAL MATERIAL & FEATURES	
5	Used by Pathway to indicate custom material and/or feature. Placed in model number in the position it relates to (eg. float/displacer, float arm extension, etc.). When used, an option number will be assigned by Pathway (see below)
(#)	Option # (in parentheses at end of model number) Pathway will assign option number unique to custom material and/or features